

F140/MN60

MALZEME TAŞIMA
KOLTUKLARI



2 NOKTALI
EMNİYET KEMERİ

KALÇA
TUTACAĞI

AĞIRLIK AYARI
KOLU

İLERİ GERİ
KIZAK KURSU



F140/MN60

F140/MN60	
Mekanik süspansiyon	●
Ağırlık ayarı	130 Kg'a kadar manuel
Süspansiyon kursu	60mm
Yükseklik ayarı	N/A
Döner tabla	▲
Kızak kursu	210mm
Bel desteği	N/A
Kalça tutamağı	▲
Ayarlanabilir / katlanabilir kolçaklar	▲
Kafalık	N/A
Arkalık ayarı	●
Vinil döşeme (Vakumlu)	●
Kumaş döşeme (Vakumlu)	▲
2 noktalı emniyet kemeri	▲
Doküman kutusu / cebi	●
Isıtıcı	▲
OPS switch (ağırlık algılayıcı sensör)	▲
Standart bağlantı eksenleri	328mm
Opsiyonel bağlantı eksenleri	320mm
Testler	EN13490 IT1,IT2 ISO 7096 EM8 ISO6683 EN1726-1

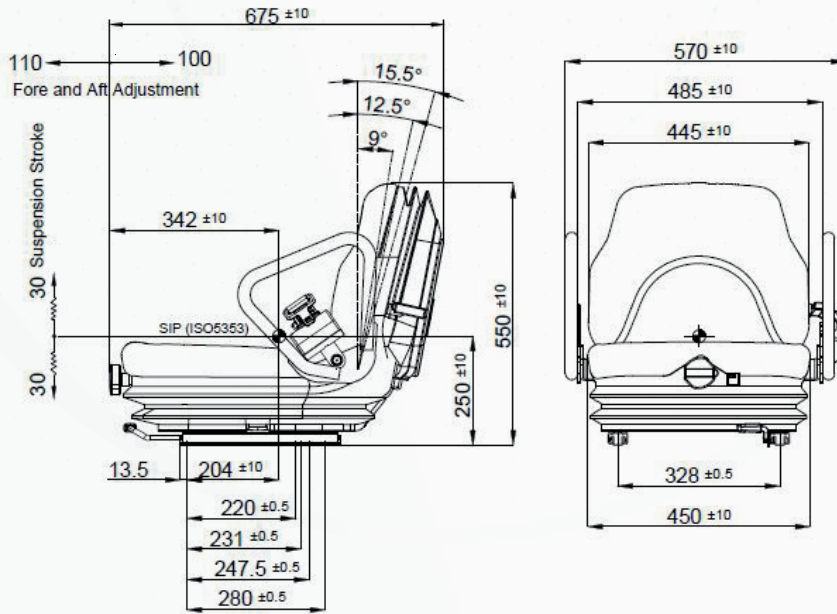

▲ : Option ● : Standard N/A : Not Available