

23/MN60

MATERIAL HANDLING 
SEATS

FOLDABLE
ARMRESTS

2PNT
SEAT BELT

BACKREST
ADJUSTMENT

WEIGHT
ADJUSTMENT

FORE AND AFT
ADJUSTMENT



23/MN60

23/MN60	
Air suspension with 12V or 24V built-in compressor	▲
Mechanical suspension	●
Weight adjustment	Manual up to 150kgs.
Suspension stroke	60mm
Optional suspension stroke	80mm
Height adjustment	N/A
Turn Table	▲
Slide travel	210mm
Lumbar adjustment	▲
Hip restraints	▲
Adjustable / Foldable armrests	▲
Adjustable headrest	▲
Backrest adjustment	●
Vinyl trim (Vacuum type)	●
Cloth trim (Vacuum type)	▲
2-point seat belt	▲
Document box-pouch	▲
Heater	▲
Operator presence switch	▲
Standard connection width	328mm
Optional connection width	320mm
Testing	EN13490 IT1,IT2 ISO 7096 - ISO 24135-1 - ISO 6683 ECE R16.08 - ISO 3795

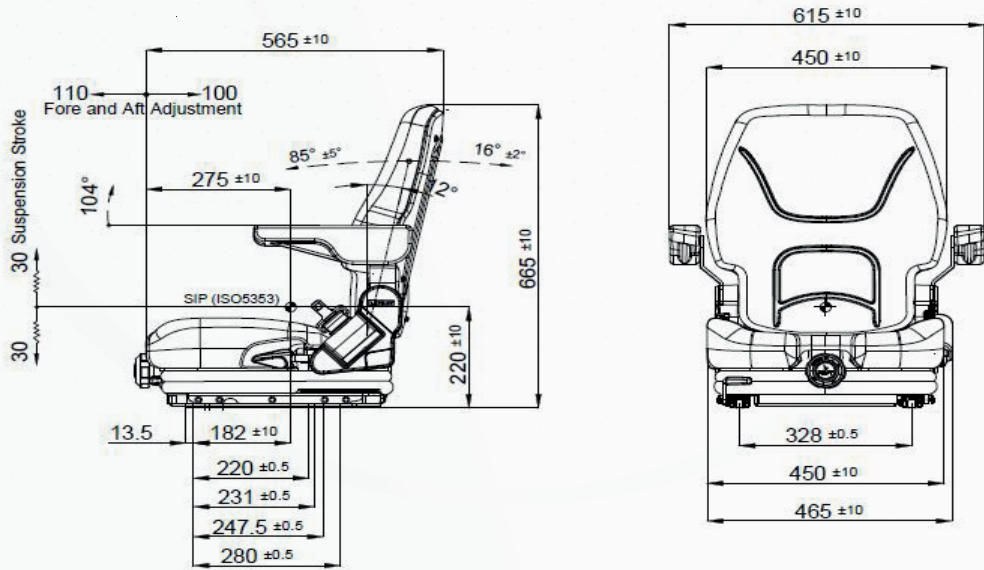

▲ : Option ● : Standard N/A : Not Available